

RAM-SET™ FEATURES:

- Automatic and Manual Mode
- Reliable Nonvolatile Memory
- Press Run/Interlock Relay
- Slide Gap Interlock
- Motion Sensing
- Slide Drift Indication
- Electronic Overtravel Limits
- Easy Keypad Data Entry
- Allows Entry of Up to 500 Die Numbers/Shut Height Values
- Self Diagnostics and Fault Code Display
- Optional Counter Balance Software
- Keylock Security
- For Use on Single and Double Action Presses
- Large LED Display
- Serial Communication
- Absolute Linear Position Feedback to .001"



DESCRIPTION:

The RAM-SET™ Press Shut Height Controller is a dedicated stand-alone system which automatically positions the press shut height to a customer predetermined location. By consistently repositioning the shut height to a known “good” value each time a die is changed, hit-to-hit times will be greatly reduced, thus saving scrap and time. Other features include relays to interface existing ram adjust up/down motor starters as well as run/inter-lock circuitry. An additional relay monitors the shut height position once it has been driven to a “good” value. The relay stays energized as long as the shut height stays within a programmed +/- window around the setpoint. If the slide “drifts” to an unacceptable value the relay will de-energize, which could be used to stop the press.

The RAM SET™ includes several auxiliary options such as serial communication in RS232 or RS485 format. The serial port can be used to upload or download information to a central computer system. An auxiliary digital output is supplied for use as a counter balance adjust device. When fed to a digital input type valve the counter balance can be changed each time the shut height value is changed in the automatic mode.

PROGRAMMING

The RAM-SET™ provides simple yet versatile keyboard programming for calibration as well as die input information. Calibration functions include:

- Transducer wire speed details. Each linear transducer has its own unique operating speed which must be calibrated for optimum performance.
- Count Direction - Used to determine increasing / decreasing counts.

- Press Type Selection - To determine if press is single action or double action (inner or outer slide). This information is needed for the slide gap interference limit operation.
- Electronic Offset - Allows transducer to be electronically zeroed to press.
- Overtravel Limit Values - Allows entry of overtravel limit upper and lower values.
- Slow Dwell - This is the method the RAM-SET™ uses to accurately position the shut height. The ram adjust relays will “pulse” when they are close to the “setpoint”. To get the optimum accuracy, the “pulse on” (duration relay stays energized) should be just long enough to get the ram adjust motor moving, and the “pulse off” (duration relay stays de-energized) should be long enough for the motor to coast to a complete stop.
- Slow Down Setpoint - Distance away from the shut height value that the relays will start pulsing.
- Drift Window - “+/-” window around the shut height value that will keep the “in position” relay energized.

DIE NUMBER PROGRAMMING:

The RAM-SET™ allows up to 500 die numbers/shut height values and counter balance values to be entered into the system. Other programming includes:

- Clear all programmed die numbers/shut height/counter balance values.
- Remove a specific die number/shut height/counter balance value.
- Review all programmed die numbers/shut height/counter balance values.

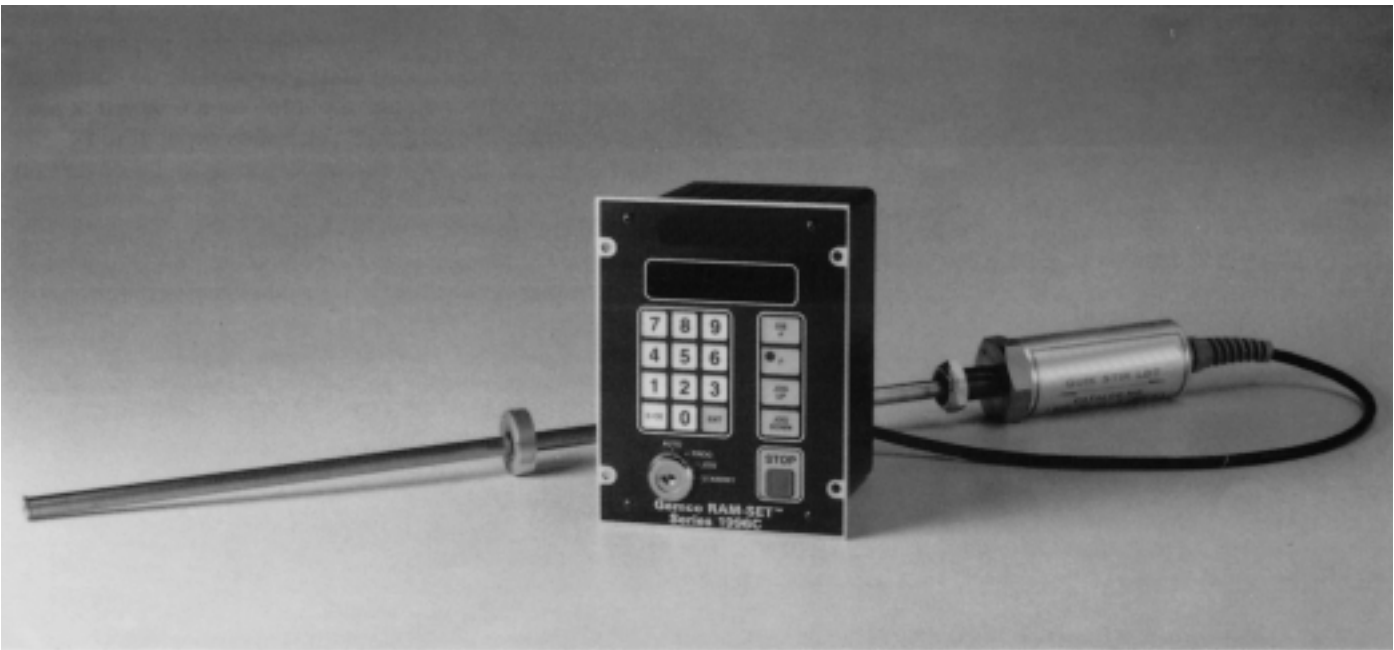

General Ordering Information:

A Series 1996C RAM-SET™ Automatic Shut Height Controller consists of a controller and output module. The linear displacement transducer and cable termination kit are ordered as separate items.

The controller is ordered as a separate item for mounting in your own enclosure or can be ordered mounted and prewired in an enclosure from the factory. To order as a separate item, assemble the controller part number specifying any applicable options and insert "X" for enclosure type.

ORDERING DETAILS:

Controller - The controller includes a keypad for programming, LED display, keylock mode select switch and I/O connection terminals for transducer input, output module connection, serial and digital outputs as well as 115 VAC input.

The output module contains relay terminals for ram adjust up/down contacts, triple pole, 10A, in-position and run interlock relays, DPDT, 10A and 115 V AC input.

Enclosure Type - The controller/monitor can be ordered as an open chassis unit for mounting in an enclosure in the field. Insert an "X" where enclosure type is specified if the open chassis version is desired. A 12 or 4 in this location specifies a NEMA 12 or NEMA 4 enclosure with room for the controller and output module or monitor only.

Cable Termination Kit - The cable termination kit is a system designed to transfer the transducer signal to the controller with the least amount of physical wear and tear. It incorporates a strain relief fitting that is welded near the transducer and a flexible cable assembly between the strain relief fitting and a junction box mounted on the crown of the press. Inside the junction box, mating quick disconnect fittings separate the flexible cable from the cable to the controller. If the flexible cable wears or is damaged, the cable can be easily replaced. Thirty-five feet of cable is provided standard between the junction box and controller.

Linear Displacement Transducer - The transducer Series 952 Blue Ox LDT, must be ordered with a specified active stroke length (measuring range). It is recommended that the length selected be the greatest possible length that will physically fit in the ram. This allows room for mechanical variations when mounting. The transducer includes a magnet and spacer. Mounting hardware kits are available.

STANDARD RAM-SET SHUT HEIGHT CATALOG NUMBERING SEQUENCE Controller with Factory Installed Hardware Options

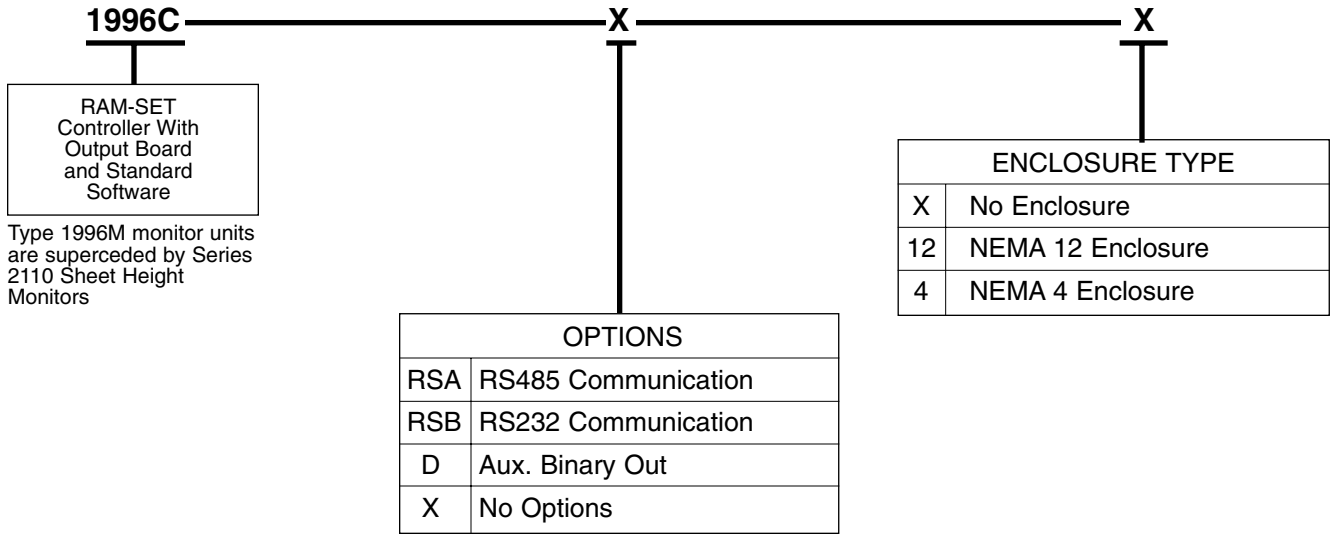

CABLE TERMINATION KIT

PART NUMBER	DESCRIPTION
SD0443800L*	Cable Termination Kit with 25 ft. J Box to Controller/Monitor Cable for 952 Probe.

*Insert Cable Length in Feet. Cable over 25 ft. requires price adder.

SPARE PARTS

PART NUMBER	DESCRIPTION
SD0403803	Spare Cable Kit Between J Box and 952 Probe
SD0402800L*	Spare Cable Kit Between J Box and Controller
SD0409600	Relay Module Assembly
SD0399900	Faceplate Assy. with Keypad
SD0397900	Mother Board
SD0398000	CPU Board
SD0398100	Power Supply Board
SD0400000	Keylock Assembly
04523020	IAC24 Relay
04522003	S.P.D.T. Relays
04522006	Triple Pole Relays
04517126	14 Place Plug in Connector
04517125	6 Place Plug in Connector

RAM-SET™ DIMENSIONS

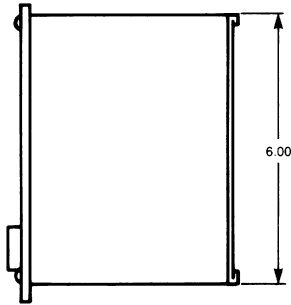
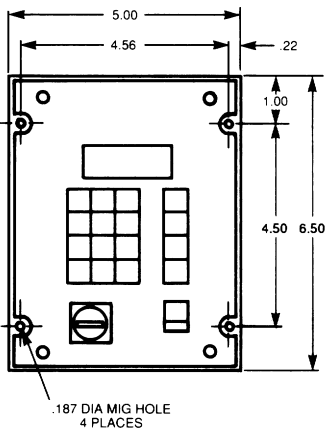
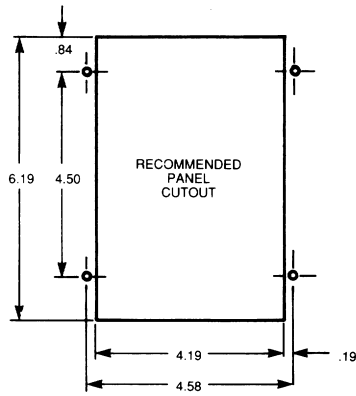
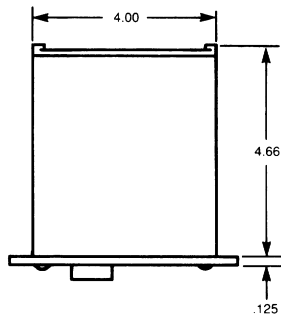

All dimensions are shown in inches.

RAM-SET™ RELAY BOARD

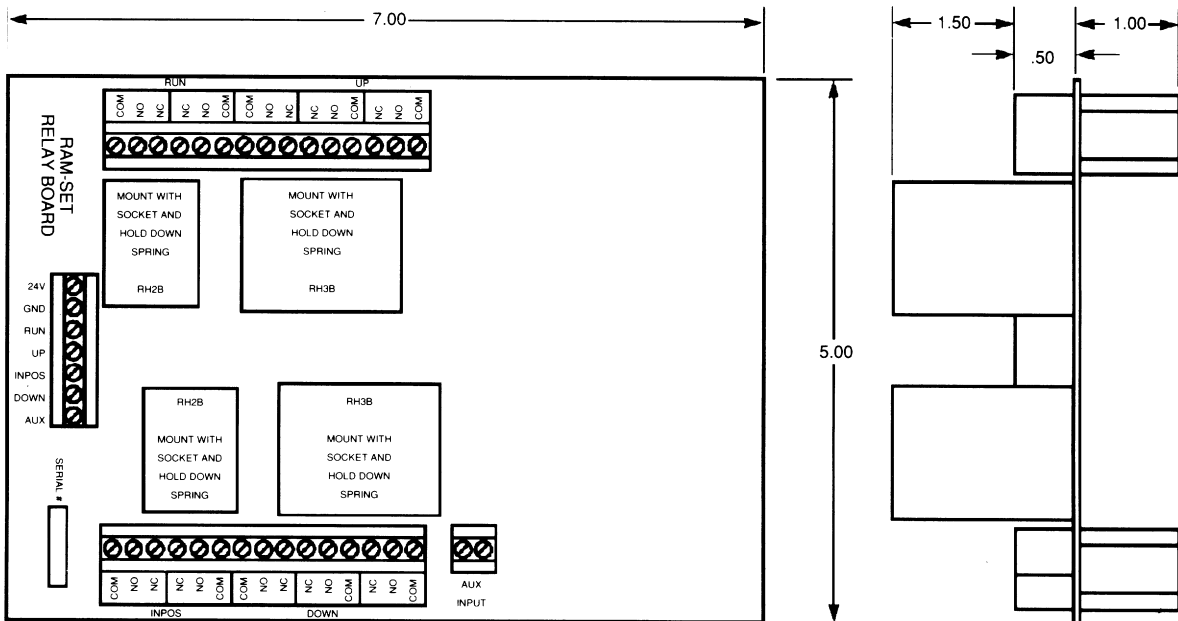

CONTROLLER ENCLOSURE DIMENSIONS

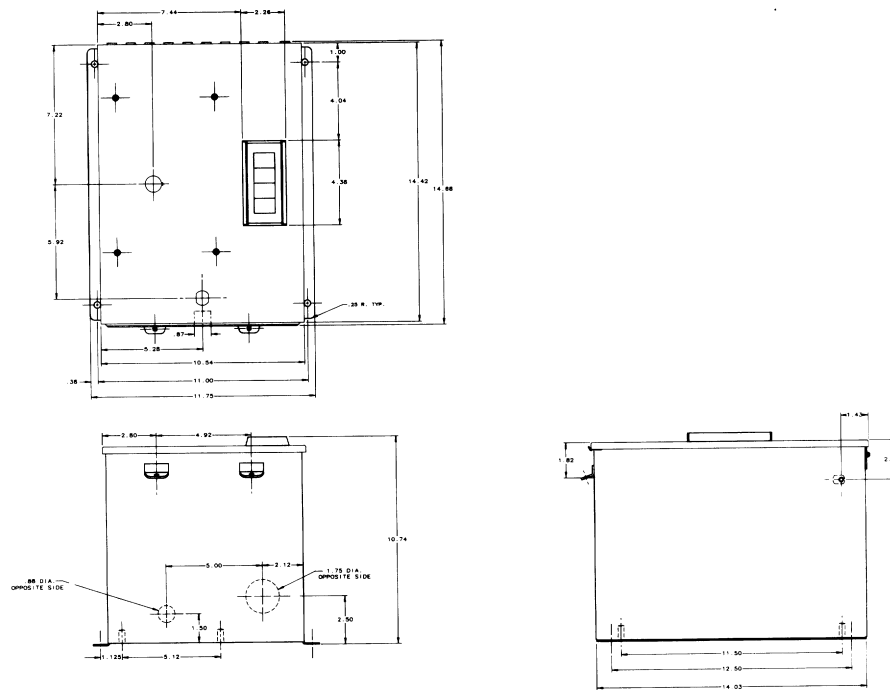

TRANSDUCER TYPICAL DIMENSIONS

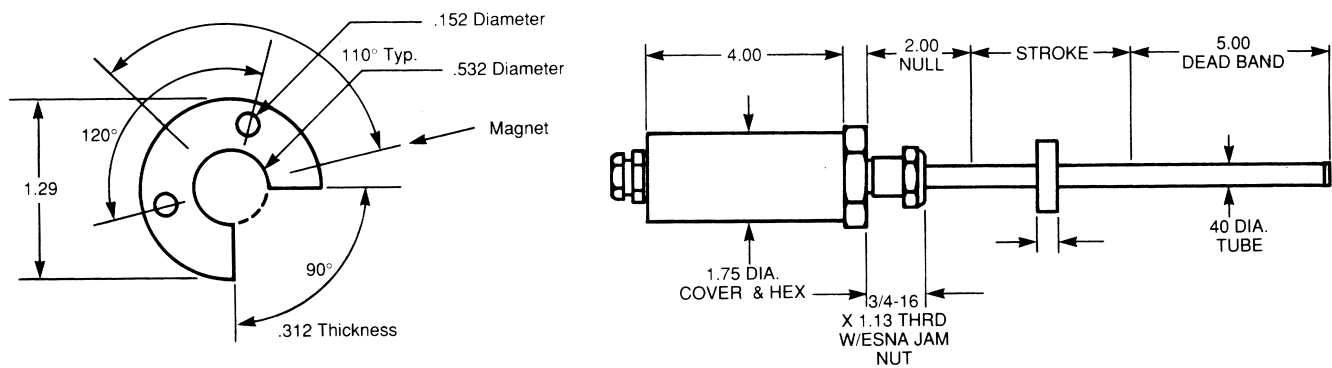

All dimensions are shown in inches.

TRANSDUCER MOUNTING:

The proper mounting of the linear displacement transducer is critical to insure proper operation of the system. While no hard and fast rule applies to mounting the transducer the following should be considered: A) The transducer should be mounted between a fixed portion of the ram (typically above the wrist pin on straight side presses) and the slide (holding the magnet). Because of variations from press to press, the transducer/magnet mounting brackets are not provided. These brackets should be made from cold rolled steel and configured such that, 1) sufficient clearance from the crown to the top of transducer is seen when the ram is at top dead center, 2) the slide bracket is no closer than 2" from the bottom of the transducer hex with the slide at its uppermost point, 3) that the linear transducer is as perpendicular to the press bed as possible and that brackets are aligned so as not to rub or side load the linear transducer when the slide is being adjusted, 4) that sufficient clearance for the linear transducer guide tube is provided when the slide is at its uppermost point.

The cable termination kit should be installed such that the flexible cable between the linear transducer and the junction box is as closely aligned as possible and that the junction box has clearance when the ram is at its uppermost point.

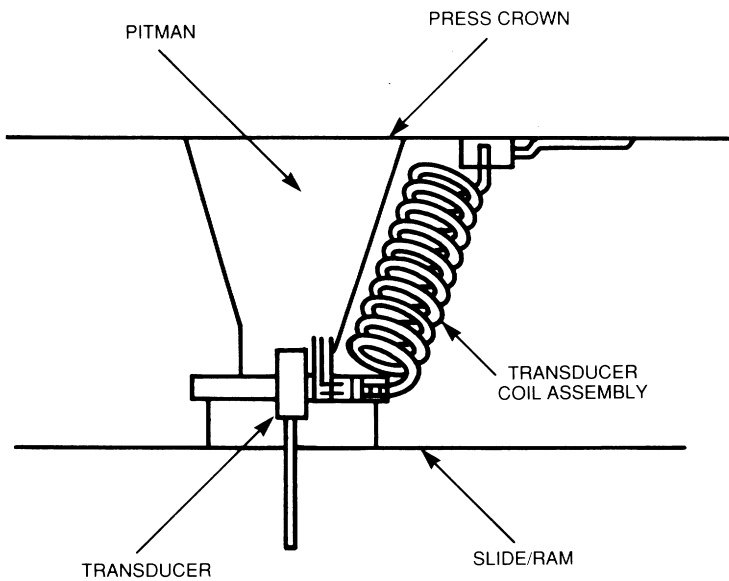
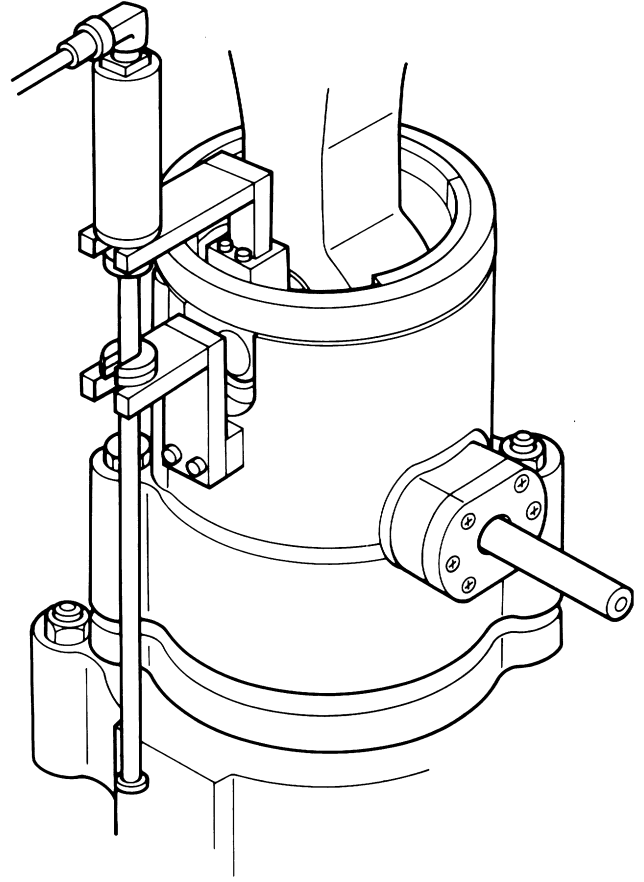

All dimensions are shown in inches.

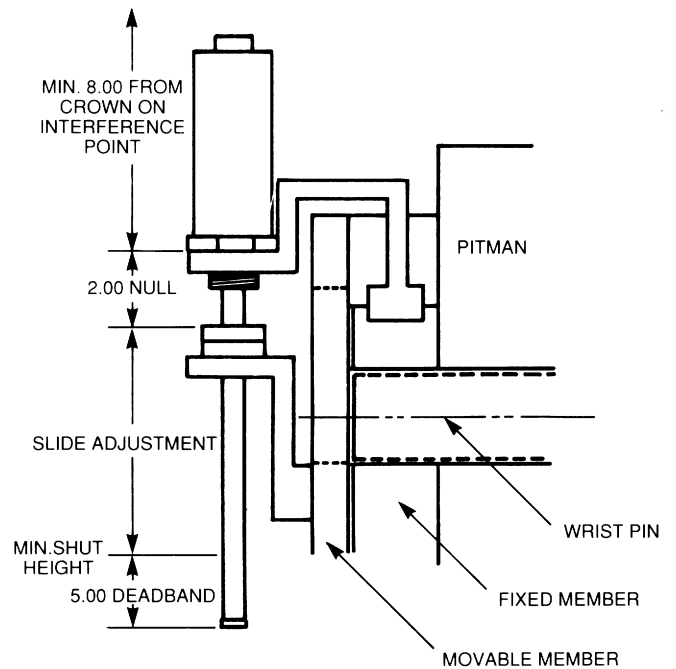

SPECIFICATIONS:

RAM SET™ CONTROLLER

Temperature Range: Operating 32°F to 120°F
Storage 0°F to 150°F

Operating Voltage: 110 - 120 VAC 50/60 Hz

DigitalOutputs: 4 Open Collector 1 -30 VDC @ 200mA maximum

RELAY OUTPUT MODULE

Input Module: 110 - 120 VAC 50/60 Hz

Output Type: 10 AMP, Mechanical Isolated Contact Relay
2 - 3PDT, 2 - DPDT

Cable Termination Kit

Catalog Number
SD0482700L25

Junction box mounts on crown of press.
Coiled cable protects and controls cable
connection to the linear transducer
mounted on upper arm



Universal Transducer Mounting Bracket

Catalog Number SD0441300

Simplifies mounting of linear displacement transducer between upper pitman
arm and ram.



AMETEK®
PATRIOT SENSORS

1080 NORTH CROOKS ROAD • CLAWSON, MI 48017 USA
800-635-0289 • 248-435-0700 • Fax 248-435-8120
www.patriotsensors.com • www.ametek.com

1996.C1
4/99 • Z30
1.5M