

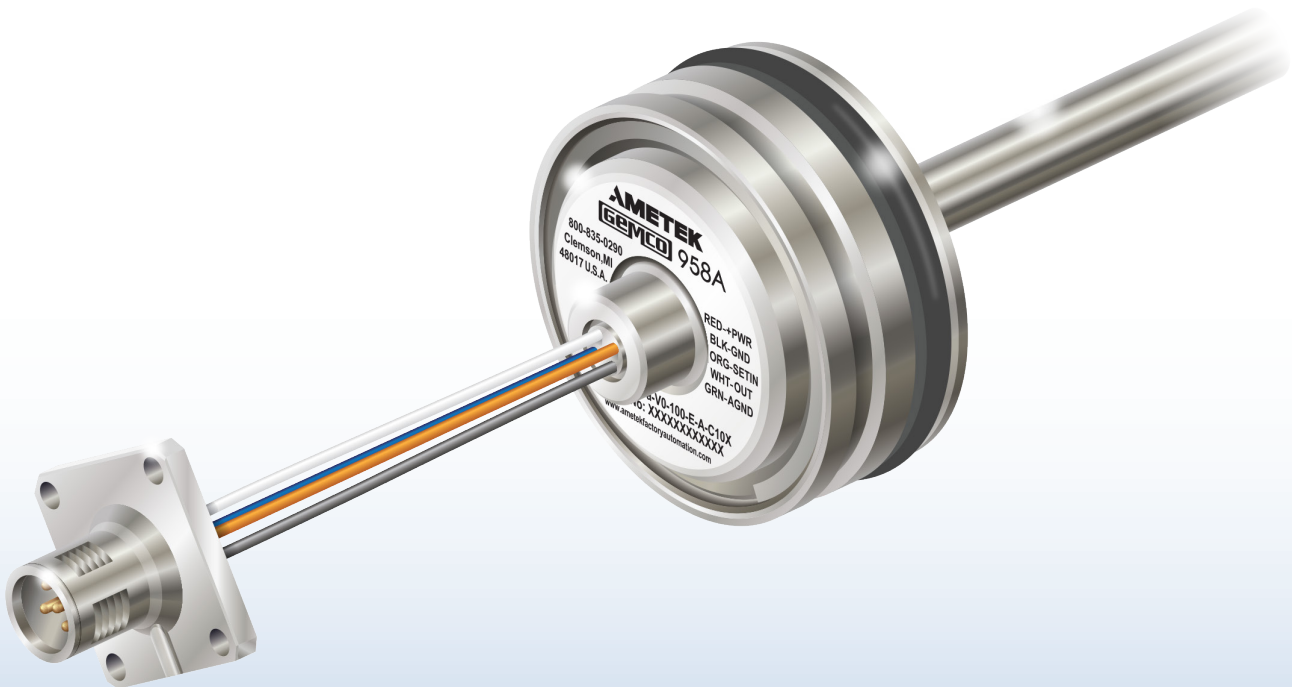

## Series 958 Embedded LDT

### Embedded Linear Displacement Transducer Installation Manual

# 958A



**ABSOLUTE PROCESS CONTROL  
KNOW WHERE YOU ARE... REGARDLESS**

# Contents

Chapter 1: 958A Overview .....	3
1.1 Dimension Drawing .....	4
Chapter 2: Installation.....	5
2.1 Installing in a Hydraulic Cylinder.....	5
2.2 Magnet Installation .....	5
2.3 Mounting .....	6
2.4 Set Screw Installation .....	6
Chapter 3: Connections & Wiring .....	7
3.1 Wiring .....	7
3.2 Pinouts and Wiring.....	8
3.3 Features – Automation Gain Control.....	9
3.4 Setting Zero & Span Positions.....	9
Appendix A: Part Numbering .....	10
Appendix B: Specifications.....	11

**NOTE:** Ametek has checked the accuracy of this manual at the time it was approved for printing. This manual may not provide all possible ways of installing and maintaining the LDT. Any errors or additional possibilities to the installation and maintenance of the LDT will be added in subsequent editions. Comments for the improvement of this manual are welcome. Ametek reserves the right to revise and redistribute the entire contents or selected pages of this manual. All rights to the contents of this manual are reserved by Ametek.

## Unpacking

Carefully remove the contents of the shipping carton and check each item on the packing slip before destroying the packing materials. Any damage must be reported to the shipping company. If you do not receive all of the parts, contact Ametek at 800-635-0289 (US and Canada) or 248-435-0700 (International).

Most probes are shipped in a Tube. To remove the metal end cap, use a large, flat blade screw driver or a metal rod and tap on the inner edge of the cap until it pivots. Grab the cap and pull it out. Use caution as the edge of the metal cap may be sharp.

If you have an RMA warranty claim, pack the probe in a shipping tube or with stiff reinforcement to prevent the probe from being bent in transit.

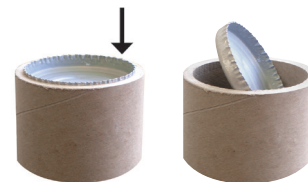

## Chapter 1: 958A Overview

We know today's industrial challenges are extreme, so we designed and built a sensor to meet and exceed these demands, regardless of the application or environment. Innovation, proprietary technology and decades of experience were the key to the development of our 958A Embedded Linear Displacement Transducer.

The 958A was designed with the mobile hydraulics market in mind. The 958A is a rugged, accurate, programmable zero & span, auto-tuning, non-contact linear displacement transducer in a compact embedded rod-style package. The embedded package style allows the unit to be totally installed inside of a hydraulic cylinder, thus protecting the transducers from outside conditions. The transducer utilizes our field-proven Magnetostrictive technology to give absolute analog position, accurate to 0.04% of the programmable sensing distance. A variety of different analog outputs are available to meet your needs.

The 958 has a variety of truly unique features. The first one is the wide power range of 8 to 30 VDC @ 1.6 watts. The LDT also has auto-tuning capability, the ability to sense a magnet other than the standard ring magnet and adjust its signal strength accordingly. Our units offer a variety of different analog outputs, all with optional field programmable Zero & Span points. Units can be ordered in English or metric span lengths from 2" to 100" (50mm to 2540mm), and come standard with either integral cable assemblies, bare leads or M12 style connectors.

The 958A units offers a unique diagnostic capability. When the magnet is present and within the programmed range the unit will output a voltage or current within its selected range (depending on location of magnet). If the magnet moves beyond the programmed ranges the output will indicate this with a voltage or current outside of the selected range.

Voltage Output Specified at time of order (i.e. in Part Number)

V0	Range	0 to +10VDC
	Resolution	16 bits (0.0015% of span)
	Fault Condition	Loss of Magnet 10.2V, below or above programmed range -0.1V or 10.1V

V1	Range	+10 to 0VDC
	Resolution	16 bits (0.0015% of span)
	Fault Condition	Loss of Magnet 10.2V, below or above programmed range 10.1V or -0.1V

V2	Range	0 to +5VDC
	Resolution	15 bits (0.0031% of span)
	Fault Condition	Loss of Magnet 5.2V, below or above programmed range -0.1V or 5.1V

V3	Range	+5 to 0VDC
	Resolution	15 bits (0.0031% of span)
	Fault Condition	Loss of Magnet 5.2V, below or above programmed range 5.1V or -0.1V

V4	Range	0.25 to +4.75VDC
	Resolution	~15 bits (0.0034% of span) (14.85 bits)
	Fault Condition	Loss of Magnet 5.2V, below or above programmed range -0.1V or 5.1V

V5	Range	+4.75 to 0.25VDC
	Resolution	~15 bits (0.0034% of span) (14.85 bits)
	Fault Condition	Loss of Magnet 5.2V, below or above programmed range 5.1V or -0.1V

V6	Range	0.5 to +4.5VDC
	Resolution	~15 bits (0.0034% of span) (14.68 bits)
	Fault Condition	Loss of Magnet 5.2V, below or above programmed range -0.1V or 5.1V

V7	Range	+4.5 to 0.5VDC
	Resolution	~15 bits (0.0034% of span) (14.68 bits)
	Fault Condition	Loss of Magnet 5.2V, below or above programmed range 5.1V or -0.1V

Curent Output Specified at time of order (i.e. in Part Number)

C2	Range	20 to 4mA
	Resolution	15.7 bits, calibrated for 3.5-21mA (0 - 21mA, 16 bits)
	Fault Condition	Loss of Magnet 3.8mA, below or above programmed range 20.1mA or 3.9mA

C4	Range	4 to 20mA
	Resolution	15.7 bits, calibrated for 3.5-21mA (0 - 21mA, 16 bits)
	Fault Condition	Loss of Magnet 3.8mA, below or above programmed range 3.9mA or 20.1mA

All units can easily be changed in the field for reverse operation. See section 3.4 Setting Zero & Span Positions.

# Series 958 Embedded Linear Displacement Transducer

## 1.1: 958A Dimension Drawing

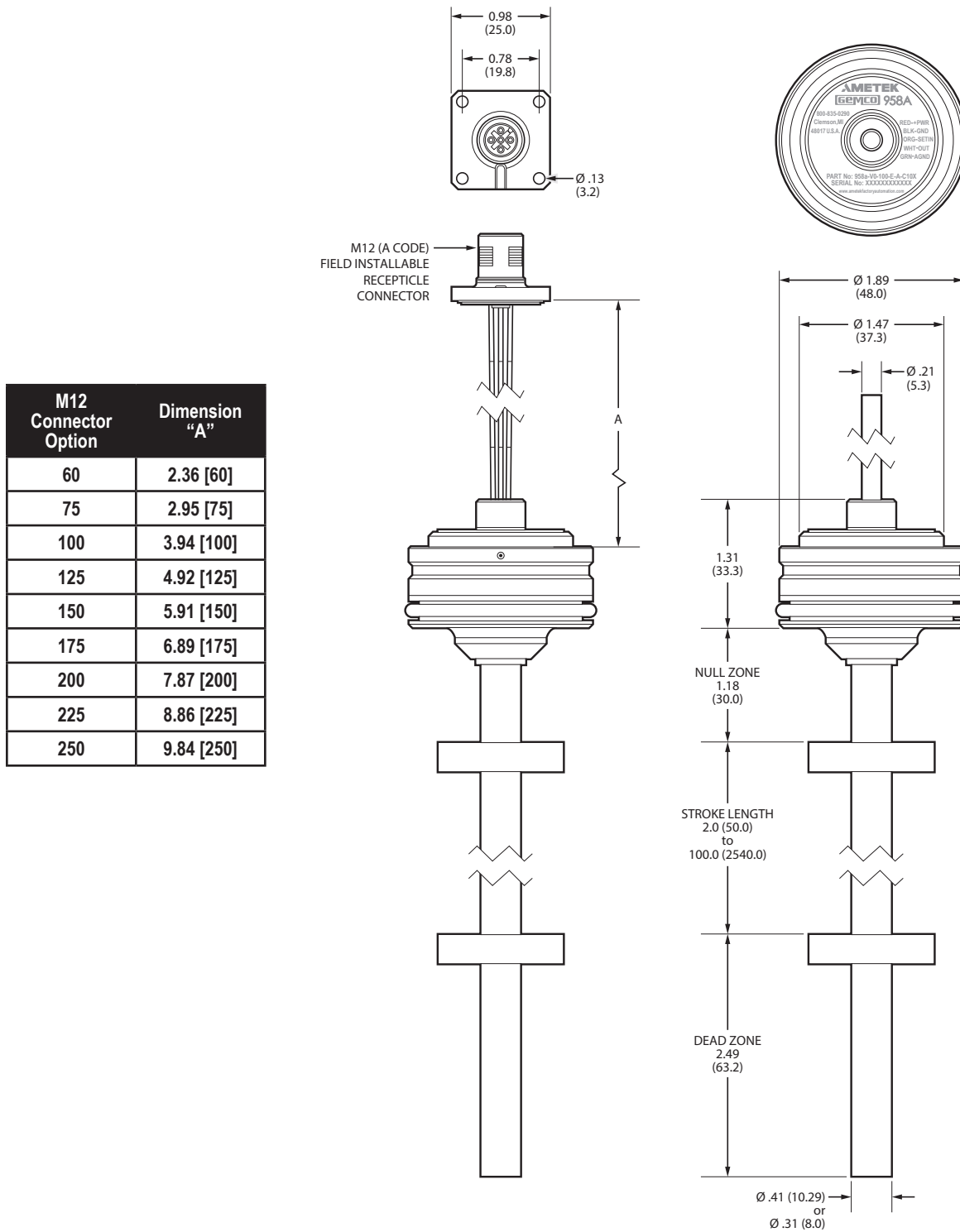
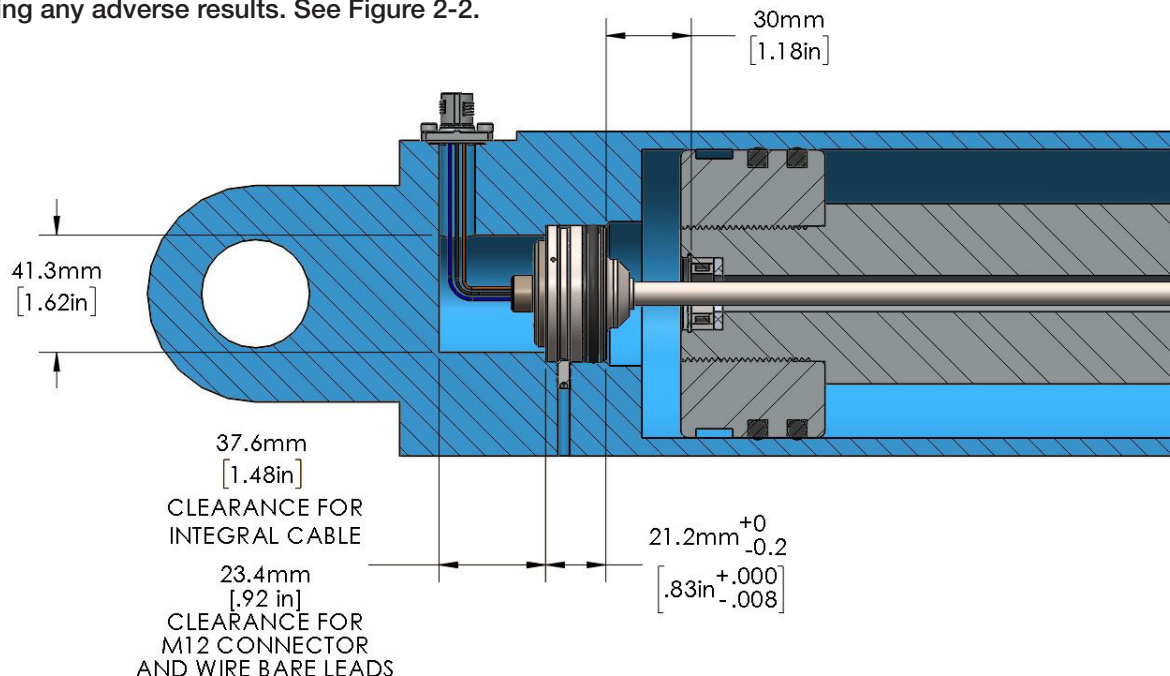

**Figure 1-1: 958A Dimension Drawing (PD-0126000)**

## Chapter 2: Installing the LDT

The 958A is designed for insertion into mobile hydraulic and clevis style cylinders. The hydraulic cylinder must be prepped for an Embedded Style Linear Transducer.

**Installation Notes:** The 958A is offered in either a 10.29mm (.405") or an 8mm (.315) diameter guide tube. There are 4 different magnet styles offered. When the magnet is installed in a ferrous material it is necessary to add a non-ferrous spacer between the magnet and piston. Non-ferrous materials, such as brass, copper, aluminum, non-magnetic stainless steel, or plastics, can be in direct contact with the magnet assembly and rod end without producing any adverse results. See Figure 2-2.



**Figure 2-1: 958A Embedded installed in hydraulic cylinder**

Drawing is for reference only. For detailed cylinder machining, contact application support.

### 2.2: Magnet Mounting Detail

Ferrous Piston

Non-Ferrous Piston

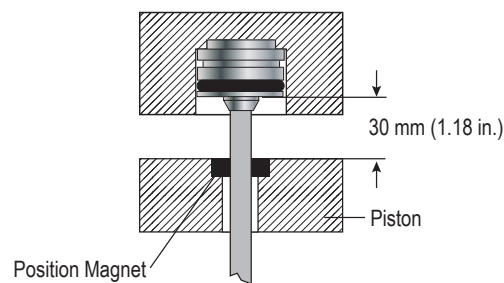
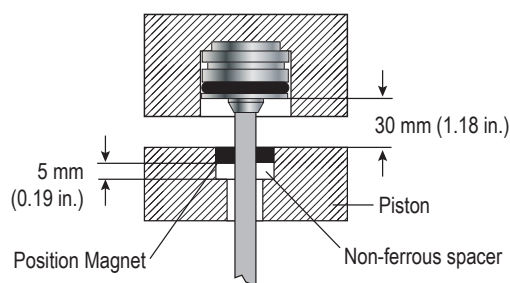

**Magnet installation in ferrous material**

**Magnet installation in non-ferrous material**

**Figure 2-2: Magnet mounting detail**

# Series 958 Embedded Linear Displacement Transducer

## 2.3: Mounting

There are 4 basis steps to install LDT into cylinder.

1. During assembly of the cylinder install LDT
2. Route cable or M12 connector through cylinder
3. Install Set screws to hold LDT in place (M5x10 max.), 3 set screws recommended at 120°. torque 0.05Nm  
See Figure 2-4 Set Screw Channel Detail
4. Insert connector into M12 shell and secure to cylinder

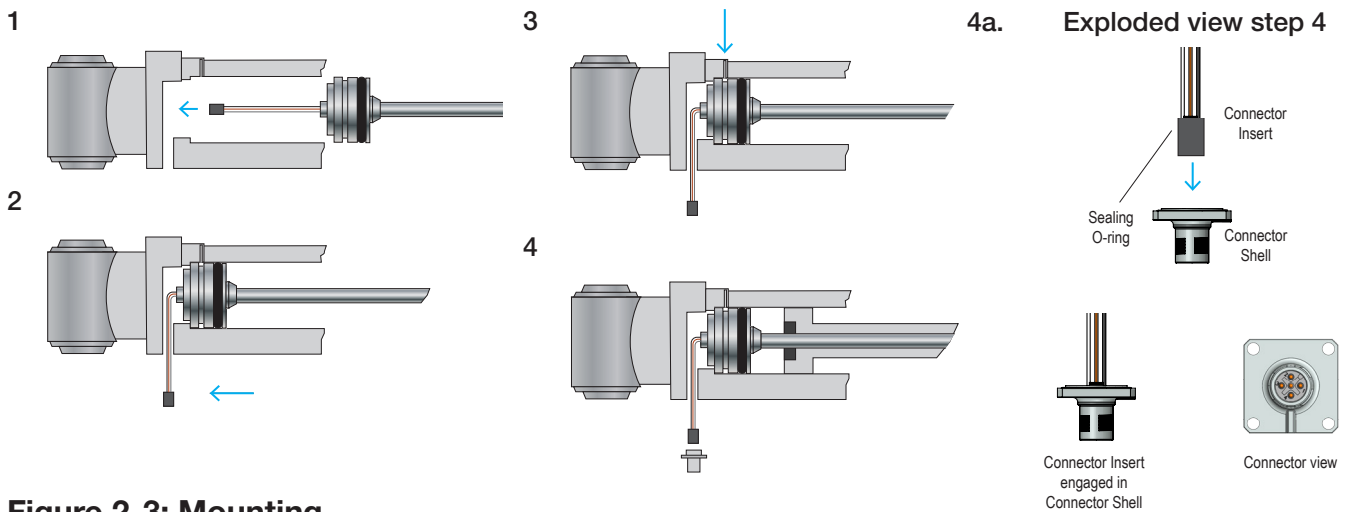
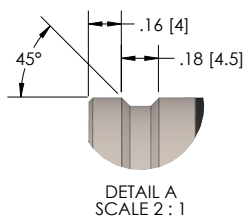

Figure 2-3: Mounting

## 2.4: Set Screw Channel Detail



Fastening: Fasten the 958A Embedded LDT into the cylinders 48mm bore, the O-ring and support ring must be in place to seal the electronics from hydraulic fluid. The housing of the transducer is fastened in place with three M5x10max (or UNC / UNF equivalent) set screws at 120° apart. Torque to 0.5Nm.

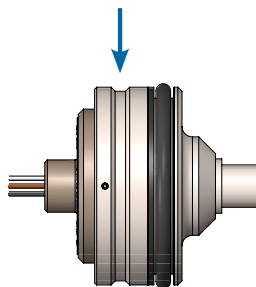

Figure 2-4: Set screw channel detail

## Chapter 3: Connections and Wiring

Once the LDT has been installed, wiring connections can be made. Units are available with Integral cable assemblies, bare leads or 5 pin M12 (A-Code) connector options. Refer to part numbering on unit in question for proper wiring. See Appendix A for part numbering grid. See Figure 3-2 for connection options.

Once the LDT has been installed, wiring connections can be made. On units with the M12 connector option it is recommended to use an industry standard 5 pin 12mm Euro style cordset with a shield tied to the coupling nut. On units with our Integral Cable option the shield is tied directly to the LDT's housing. To reduce electrical noise the shield must be properly used. Connect the cable's shield to the controller system Ground. Always observe proper grounding techniques and isolate high voltage (i.e. 120/240VAC) from low voltage (i.e. 24 VDC cables).

**Warning: Do not use molded cordsets with LEDs!**

It is preferable that the cable between the LDT and the interface device be one continuous run. If you are using a junction box, it is recommended that the splice junction box be free of AC and/or DC transient-producing lines. The shield should be carried through the splice and terminated at the interface device end.

**NOTE:** When grounding the LDT, a single earth ground should be connected to the Power Supply Common (circuit ground). The LDT Power Supply Common should be connected to the Power Supply Common (-) terminal. The LDT power supply (+VDC) should be connected to the power supply positive terminal (+). The LDT cable shield should be tied to earth ground at the power supply. The LDT analog common should not be connected to earth ground and should be used for connection to interface devices only.

The 958A offers up to 16-Bits of resolution, and is fully programmable over the entire active stroke length. Keep in mind that there is a 1.18" Null Zone at the connector end of the LDT and a 2.49" Dead Band at the other end of the LDT that the magnet must stay out of at all times. The units come fully programmed from the factory and do not require re-programming unless desired.

The analog output is referenced to the analog common terminal and should not be referenced to any of the other common terminals. For wiring, see Figure 3-1. For programming Zero and Span, See Section 3.4.

### 3.1: Wiring

Figure 3-1 shows two common methods for wiring the 958A to a customer supplied interface device, such as a PLC or motion controller. The two different methods are commonly referred to as Single Ended Input and Differential Input. Differential Input is the preferred wiring method.

With the Differential Input, the Analog Common wire is connected to the customer supplied input device and the Power Supply Common is wired separately to the customer's supplied power source. When wired using the Differential method, the electrical noise and voltage offset errors produced by the currents running through the Power Supply Common are eliminated. The Power Supply Common and Analog Common are internally connected inside of the 958A LDT.

# Series 958 Embedded Linear Displacement Transducer

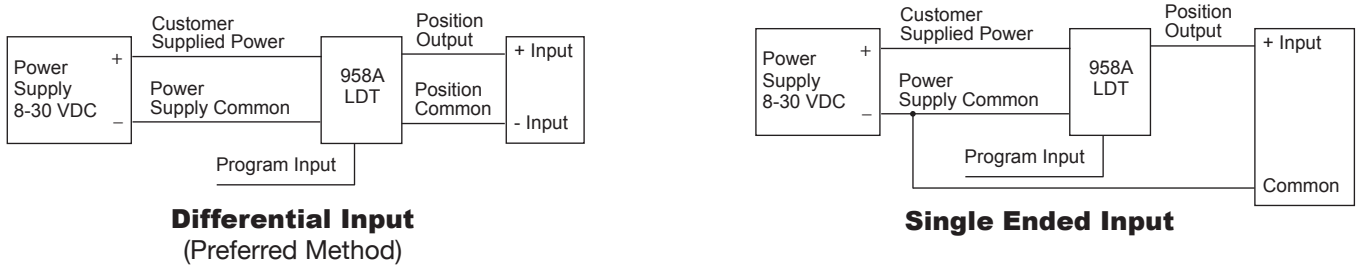
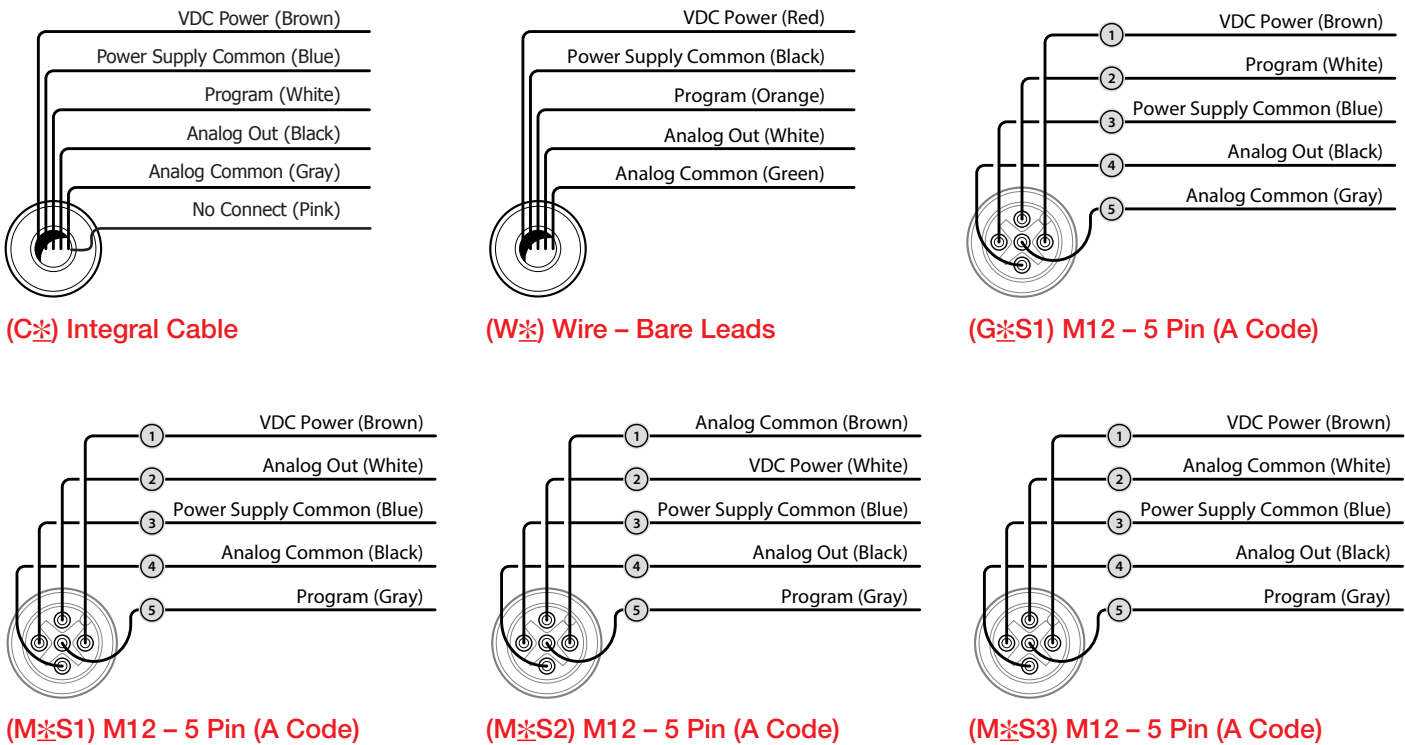

**Figure 3-1: Wiring – Single Ended vs. Differential**

The 958A-C is current sourcing, which allows the current to flow from the LDT into the user’s equipment.

## 3.2: Pinouts and Wiring

There are six different connection options available. Refer to part numbers on unit in question for proper wiring.



\* indicates wire length. Refer to part numbers Appendix A for available options

**Figure 3-2: Pinouts and Wiring**

Cable Specifications				
Cable Type	Gauge	Jacket	Temp	Bend Radius
Multi-conductor Shielded	26	PUR	-40° to 90°C	Fixed Applications 1.05" Moving Applications 3.15"

### 3.3: Features

#### Automatic Gain Control

The Automatic Gain Control feature will automatically search and find the magnet on power up and adjust the signal strength to the optimum setting. If power is applied without a magnet on the LDT, the LDT will go into a fault condition and transmit a voltage or current outside of the programmed range. See Chapter 1: 958A Overview, for list of fault conditions and outputs. To correct this, turn power off and place magnet within the active stroke area, re-apply power.

#### 3.4: Setting Zero & Span Positions

As an option the 958A can be ordered with Programmable Zero & Span positions. See page 10 part numbering to see if this option filed was selected. *Note: If option "P" was not selected in part number configuration, the unit is non-programmable.*

All units come fully programmed from the factory and do not require re-programming unless desired. The units are 100% absolute and will not lose programmed parameters on power loss. The Zero and Span points can be programmed in any order and anywhere within the LDT's active sensor area.

**NOTE 1:** Zero or Span can be adjusted individually without setting the other.

**NOTE 2:** Zero = 0V on 0-10 VDC, 0V on 0-5 VDC, .25 on .25-4.75 VDC, .5 on .5-4.5 VDC units and 4mA on 4-20mA units.

There is a timing sequence that is used to unlock the probe for programming. This is to insure that the Zero or Span positions cannot be accidentally re-programmed by someone in the field.

#### Manual Setting of Zero & Span

To set the Zero and Span position, follow these steps:

1. Apply power to the LDT.
2. Place magnet assembly where Zero is to be located, but within the active region of the probe.
3. Short the Program Input pin to the Power Supply Common for 4 seconds. Remove the short for 1 second. Within 5 seconds, short the Programming Input pin to the Power Supply Common. This completes the Zero programming process.
4. Place magnet assembly where Span is to be located, but within the active region of the probe.
5. Short the Program Input pin to the Power Supply Common for 4 seconds. Remove the short for 1 second. Within 5 seconds, short the Programming Input pin to the Power Supply +VDC.

This completes the programming process.

**NOTE:** The LDT must be unlocked to program the Zero and unlocked again to program the Span. Once either the Zero or Span is programmed the LDT will go back into the locked mode.



**WARNING:** During normal operation, electrically insulate the Program wire to prevent accidental setting of Span.

# Series 958 Embedded Linear Displacement Transducer

## Appendix A: Part Numbering

The 958A Embedded LDT is available with a number of analog outputs and connector options. The numbering scheme listed below will break down all available options. The "Unit of Measure" field will allow you to select either inches or millimeters for the stroke length.

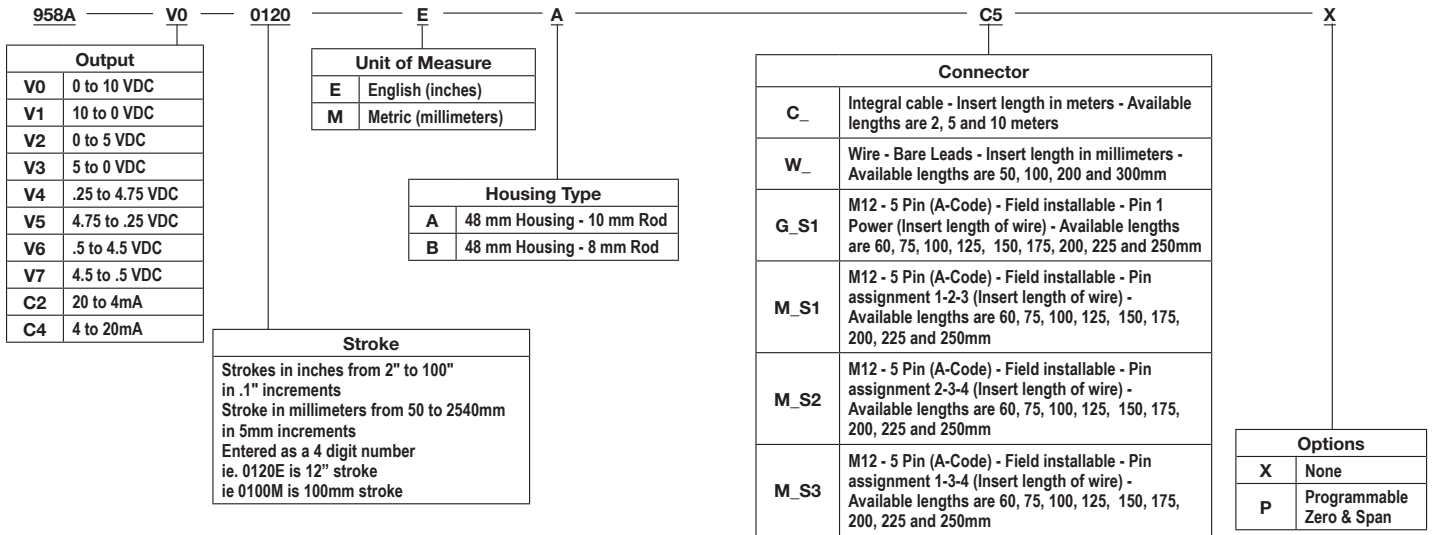

## Accessories – Magnets and Cables

There are 4 magnet choices available for the 958 Series. Magnets and magnet spacers must be ordered as separate line items.

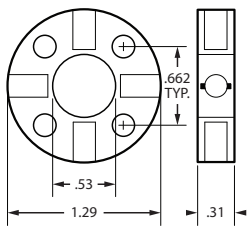

Standard 4 Hole Magnet  
P/N: SD0400800

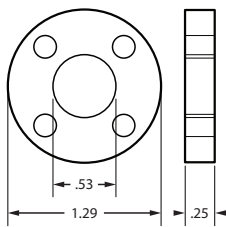

Non-Ferrous Spacer for 4 Hole Magnet  
P/N: M0822400

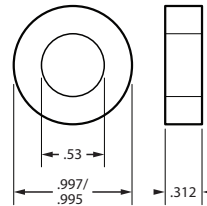

1" Cylinder Magnet  
P/N: SD0410300

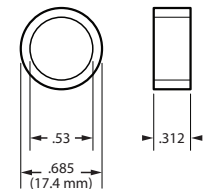

17.4 mm Cylinder Magnet  
P/N: 04588105

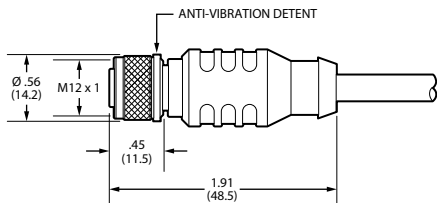

### Straight Connector

Cable M12-A Straight to flying leads – Shielded  
2 meter: 949045L2M  
5 meter: 949045L5M  
10 meter: 949045L10M

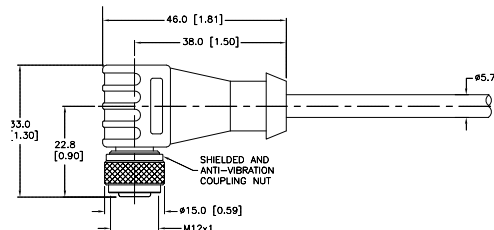

### Right Angle Connector

Cable M12-A Right Angle to flying leads – Shielded  
2 meter: 949046L2M  
5 meter: 949046L5M  
10 meter: 949046L10M

## Appendix B: Specifications

General Specifications	
Displacement	2" to 100" (50mm to 2540mm) in .1" or 5mm increments

Performance Specifications - Measurement	
Linearity	+/-0.04% of Span or +/-0.008", whichever is greater
Hysteresis	0.001" maximum
Repeatability	Equal to Resolution of output signal, +/-0.01% of Span or 0.001", whichever is greater
Update Time	0.5 ms minimum, proportional to length of LDT - not to exceed 4ms

Null & Dead Bands	
Null	1.18" (30mm) from flat face of LDT housing
Dead	2.49" (63.25mm) from end of rod

Mechanical Specifications - Housing	
Material - Housing	Stainless Steel 1.4305 / AISI 303
Diameter	1.89" (48mm)
Length (width)	1.31" (33.3mm)
Guide Tube Material	Stainless Steel 1.4404 / AISI 316/316L
Diameter - Guide Tube	8mm & 10mm (10.29mm actual)
Guide Tube Pressure	
Continuous	10mm - 5,076 PSI (350 bar)
	8mm - 4,351 PSI (300 bar)
Spike	10mm - 10,000 PSI (689 bar)
	8mm - 5,801 PSI (400 bar)
Housing (O-ring)	5,076 PSI (350 bar)

Temperature	
Head - Electronics	-40°C to + 85°C
Guide Tube	-40°C to + 105°C
Storage	-40°C to + 105°C

Shock & Vibration	
Shock	1,000 G's, single hit (per IEC 60068-2-27)
Vibration	30 G's, 10Hz - 2kHz (per IEC 60068-2-6)

Ingress Protection	
Protection level	IP68 (per EN 60529)

Electrical Specifications	
Power Consumption	1.6 Watt maximum (50mA @ 24VDC typical)
Input Voltage	8 to 30VDC

## Series 958 Embedded Linear Displacement Transducer

Protection	
Polarity	Reverse polarity protected
Overvoltage	Transient overvoltage protection to +33VDC

Output Resolution	
0 to 10VDC	16 bits (0.0015% of span)
0 to 5VDC	15 bits (0.0031% of span)
0.25 to +4.75VDC	~15 bits (0.0034% of span)
0.5 to +4.5VDC	~15 bits (0.0034% of span)
4 to 20mA	15.7 bits, calibrated for 3.5-21mA (0 - 21mA, 16 bits)

Output Loading	
Voltage	2k $\Omega$ minimum
Current	500 $\Omega$ maximum

Connection Options	
Integral Cable	Multi-conductor, 26 AWG, shielded, PUR jacket (-40° C to +90° C)
5 Pin - M12	A-Code, Shell installed from "outside" cylinder (IEC 61076-2-101)
Wire - Bare Leads	Multi-conductor, 26 AWG

Isolation	
Housing to any signal	500V

Approvals	
CE (Electromagnetic Compatibility)	2014/30/EU - When installed in grounded metal housing
RoHS 2	2011/65/EU
Electromagnetic compatibility - Part 6-4: Generic standards – Emission standards for industrial environments	EN61000-6-4
Electromagnetic compatibility (EMC) - Part 6-2: Generic standards – Immunity for industrial environments	EN61000-6-2
Agricultural and forestry machinery	ISO 14982:1998
Road vehicles - electrical disturbances from narrowband radiated electromagnetic energy — Part 5: Stripline	ISO 11452-5
Road vehicles - Electrical disturbances from conduction and coupling	ISO 7637-1/2/3
Earthmoving Machinery	ISO 13766
Industrial Trucks	EN 12895
Railway Applications	EN 50121-3-2

## 953 VMAX LDT

- Shock resistant to 1000Gs
- Vibration resistant to 30Gs
- Analog outputs, 0-10 VDC, +/-10 VDC, 0-5 VDC, +/-5 VDC, 4-20mA
- Digital output Start/Stop, Control Pulse, and Variable Pulse (PWM)
- SSI (Synchronous Serial Interface) 24, 25, or 26 Bit, Binary or Gray Code, Synchronous or Asynchronous Mode
- Removable cartridge
- IP68 rating
- Stroke length to 300"
- Input power range is 7 to 30 VDC
- Programmable zero and span
- Diagnostic Tri-Color LED



## 955 BRIK

- Low profile LDT
- Analog output 4-20mA, 0-10 VDC, +/-10 VDC, digital and quadrature outputs
- Programmable zero and span
- Stroke length to 180"
- Wide input voltage range
- Optional floating magnet
- Diagnostic LED

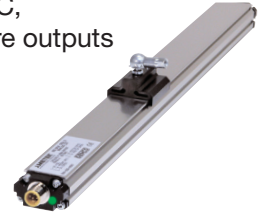

## Other Products



LINEAR DISPLACEMENT TRANSDUCERS

PLC INTERFACE PRODUCTS

ROTARY POSITION PRODUCTS

PROGRAMMABLE LIMIT SWITCHES

EXTREME DUTY CABLE REEL PRODUCTS

ROTARY LIMIT SWITCHES

RESOLVERS

MILL DUTY ENCLOSURES

ULTRA HIGH SPEED PLS

SAFETY PRODUCTS

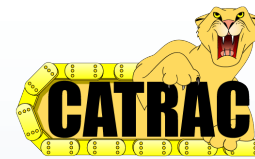

MADE IN AMERICA

Copyright 2017 by AMETEK FACTORY AUTOMATION. All Rights Reserved. Made in the USA.