

Industrial Brakes

Magnetic Shoe Brakes

Installation and Service Instructions

Type TM and TMR * with Rectifier Available for AC Operation

DC Magnetic Shoe Brakes

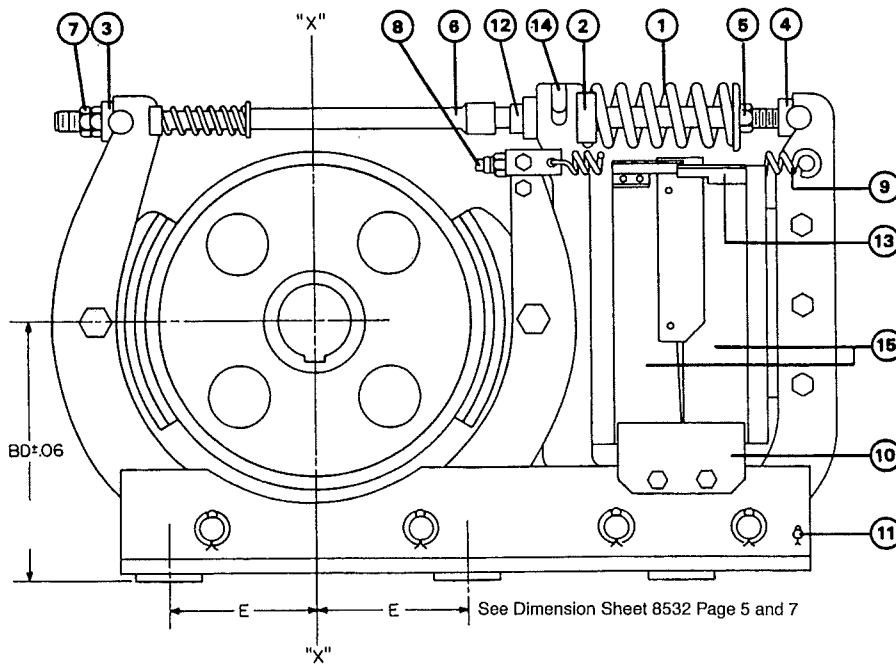

- | | |
|---------------------------|---------------------------|
| ① Main Spring | ⑨ Tension Springs |
| ② Main Spring Trunnion | ⑩ Magnet Travel Equalizer |
| ③ Shoe Arm Trunnion | ⑪ Stop Pin |
| ④ Magnet End Trunnion | ⑫ Manual Release Bushing |
| ⑤ Torque Adjustment Nut | ⑬ Travel Indicator |
| ⑥ Main Tie Rod | ⑭ Lifting Lugs |
| ⑦ Outside Shoe Adjustment | ⑮ Magnet |
| ⑧ Inside Shoe Adjustment | |

Figure 1

Description

The Type TM Brakes have a direct-current clapper type magnet and are designed so that when the magnet is energized, the shoes will clear the wheel and when de-energized, the shoes are pressed against the wheel by means of a compression spring. The force of the compression spring produces equal pressure of the shoes against the wheel and movement of the magnet results in equal movement of the shoes. Simple, rugged construction allows full accessibility of all parts for visual inspection or maintenance.

Operation (See Figure 1)

Compression spring 1 is contained between trunnion block 2 and nut 5 on tie rod 6 which passes through a clearance hole in trunnion blocks 2 and 3 and is threaded and pinned to block 4. The amount of spring force is adjusted by position of nut 5.

When brake is de-energized, main spring 1 exerts force on nut 5 and trunnion block 2 which, in effect, pulls trunnion 3 and the left shoe arm towards the wheel and pushes trunnion 2 and the inside armature which acts on bolt 8 and forces the inside shoe arms and shoes against the wheel. Geometry of the linkage is such that the shoe forces are exactly equal.

When brake is energized, magnet faces are pulled together by magnetic force moving trunnion blocks 2 and 4 towards each other by amount of magnet travel. Spring force is contained between trunnion block 2 and lock nut 5. Right magnet arm pushes outside shoe arm away from wheel and tension springs 9 cause inside shoe arms to follow movement of inside armature away from wheel.

Two adjustments are required during normal service. Nuts 7 and bolt 8 are turned clockwise to compensate for lining wear on outside and inside shoes respectively. Spring compression is adjusted for nameplate torque rating at factory. Readjustment at points 7 and 8 for lining wear will automatically bring spring compression back to initial setting.

* TMR denotes a TM Style Shunt Brake utilized with a rectifier.

Installation and Service Instructions Type TM and TMR

with Rectifier Available for AC Operation

Mounting

Brake must be mounted on a flat surface parallel to shaft whose distance from center line of shaft agrees with BD dimensions for given frame within limits of $\pm .06"$. Center line X-X should pass midway between mounting holes within $.06"$.

Frame	BD	Frame	BD
43	4.25	1665	12.13
63	5	1985	13.25
83	7	2311	15.88
1035	8.38	3014	20.75
1355	9.88		

To remove wheel from brake as received, turn manual release bushing 12 out of trunnion block 2 to jack against collar on tie rod. Continue to turn bushing until wheel is free. If desired, the complete tie rod assembly may be lifted from brake by loosening adjustment nuts 7 until trunnion block 3 may clear half bearing in outside shoe arms. Push tie rod towards outside magnet arms until trunnion block 2 is free of its bearing and lift out complete tie rod assembly. The brake may be mounted without removing the tie rod assembly depending on personal preference. Lift wheel from brake and mount on shaft using tapered key provided if wheel has straight bore and tapered keyway. Loosen shoe bolts and make sure bolt heads will be on side away from motor to allow future shoe removal for re-lining. Lift brake into position on bedplate using hooks or sling under lifting lugs on inside armature. Insert hold-down bolts hand tight and align brake square with wheel. If tie rod was previously removed, re-install using reverse technique from that described for removal. With tie rod in place, turn manual release bushing 12 back into trunnion 2 and jam tight to lock in place. Force of main spring is now holding shoes on wheel. Tighten hold-down bolts. Tighten shoe bolts.

Remove conduit box cover on shunt brakes. Bring in two power leads and connect to two bare terminals in box and tape leads. For minimum current on shunt brakes, jumper connection to place coils in series for cumulative magnetic flux is made at factory and leads are taped. Connection need not be disturbed except if coil is to be removed from brake. After making power connection, leave sufficient slack in coil leads outside of conduit box and replace conduit box cover.

For brake with high current series coils, one set of coil leads is brought out to each side of the brake and clamped. Connect line to brake coil leads and tape to insulate. Series coils are connected at the factory so that one-half of the line current flows through each coil.

Adjustment; Frames 83 through 3014

Equalizer stop block 10 is intended to insure approximately equal movement of both shoes should the brake be mounted on a surface other than horizontal, or if undue friction should occur at one of the pivot points. Normally, when the brake is properly adjusted, and linkage is free from binding, stop block 10 has no function. Brake linkage is simple to understand and adjustments are not critical. With some practice, the average maintenance person should be able to adjust the brake completely by eye without aid of measuring instruments.

To adjust the brake, only setting of nuts 7 and bolt 8 need to be changed for the outside or inside shoe. When properly adjusted with brake de-energized, the air gap between the tops of the magnets should agree with the nameplate reading (may be observed by lifting part of rubber dust shield off magnet). Magnets should be approximately centered with stop 10. This may be done visually, or if in doubt, with a feeler gauge. Actual adjustment is accomplished as follows:

Lift one side of rubber dust shield off dowel pins, exposing top of magnets.

Loosen lock nuts at 7 and 8, and turn 7 and 8 to reduce air gap to approximately the amount given on the nameplate.

At this time, magnets should be approximately centered about equalizer stop block 10. Replace rubber dust shield on dowel pins and tighten lock nuts at 7 and 8. Compressed length of main spring has automatically been brought back to that given point on the nameplate. When energized, brake shoes should have adequate movement to clear wheel at operating temperature without dragging.

Frames 43 and 63

These smaller frame sizes have a single coil, as opposed to the larger frames which have two. The inside shoe adjustment for lining wear is the only difference between the smaller frames, and larger frames, otherwise, the adjustments are identical. When adjusting the inside shoe, loosen the shoe bolt prior to making an adjustment at bolt 8. Re-tighten shoe bolts securely after making the adjustment.

Re-adjustment for Lining Wear

For optimum operation, brakes of any manufacture should be re-adjusted to normal magnet travel as often as a reasonable maintenance schedule will allow. Minimum travel will result in fastest, quietest operation with the least amount of shock and bearing wear. The TM brake will operate at a long travel, and if necessary, allows considerable lining wear between adjustments. In lieu of a maintenance schedule, travel indicator brackets 13 on top of the magnet may be used

DC Magnetic Shoe Brakes

as a visual guide for maximum wear allowable between adjustments. When magnet gap opening progresses to the point where ends of indicator brackets line up, as in figure 2, it is time to re-adjust for lining wear (see Adjustment, below).

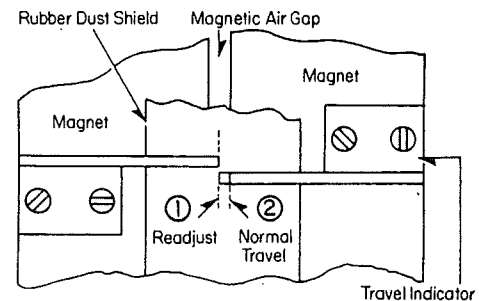

Figure 2: Magnet Travel Indicator

Figure 2: Magnet Travel Indicator

Torque Adjustment

Brake is adjusted at the factory for maximum torque rating for voltage as given on nameplate. With brake de-energized, and magnet air gap adjusted for normal travel, compressed length of spring should be per value in Table 1. Re-adjustment for lining wear will automatically return spring compression to original setting. If reduced torque is required, back off nut 5 until desired torque is obtained.

Table 1

Frame	Magnet Normal Travel	Torque Lbs. Ft.	Compressed Length Spring	Free Length Spring
43	.06	15	2.81	3.26
		25	2.63	
63	.06	40	3.38	4.0
		50	3.25	
83	.06	65	4.31	5.0
		75	4.25	
		100	4	
1035	.06	130	4.31	5.0
		150	4.25	
		200	4	
1355	.13	365	5.44	6.0
		400	5.38	
		550	5.12	
1665	.13	650	5.38	6.0
		750	5.31	
		1000	5.13	
1985	.13	1300	6.44	7.0
		1500	6.31	
		2000	6.13	
2311	.16	2600	8.38	9.0
		3000	8.31	
		4000	8.13	
3014	.19	6000	9.69	10.26
		6750	9.63	
		9000	9.5	

Installation and Service Instructions Type TM and TMR

with Rectifier Available for AC Operation

Manual Release and Relining Shoes

Brake may be released with a wrench for maintenance by turning release bushing 12 out of trunnion block 2 to jack against collar on tie rod until wheel is free. To return brake to normal operation, screw bushing 12 back into block 2 and jam tight to lock out of way.

To remove shoes for relining, release brake manually and remove tie rod assembly. Remove shoe bolts and slide shoes out around wheel. After relining shoes, reassemble shoes and tie rod and readjust brake. Stow manual release bushing back into block 2. Tighten shoe bolts.

To lift wheel and motor armature vertically, release brake manually and remove tie rod assembly. Remove bolts holding equalizer stop block 10 in place and lean magnets back against stop pin 11. Lift out wheel. After replacing wheel, move magnets back to normal position, replace equalizer block, center approximately between magnets and bolt up tight. Replace tie rod assembly and stow manual release bushing in trunnion block 2.

Coil Connection

The Type TM Brake has two identical coils integrally cast with the magnet outer ring and center core in epoxy resin. Damaged or defective coils are not repairable and must be replaced with the steel parts as a unit. Coils are attached to the brake armatures and each moves one-half of the length of the magnet air gap each time the brake operates. Coil leads are of highly flexible insulated cable. These leads are connected to the coil terminals and covered with permatex gasket compound at bottom of coil and extend to terminal board or junction box at side of brake for customer's connection. If broken or damaged, coil leads are easily replaced.

At installation, power leads are brought into conduit box or terminal board at side of brake and connected to two bare terminals. Two coil leads are already connected at the factory for cumulative magnetic flux. This connection need not be disturbed except when removing coil from brake. After making line connection, leave sufficient slack in leads between coil and conduit box to allow free movement of leads with magnet motion.

Shunt Coil Operation - Shunt brakes are usually supplied with low voltage coils for speedy action unless otherwise specified, and it is necessary to have a resistance in series with the coil. Coil voltage and value of series resistance is given in Table 2. Coils are connected per Figure 3 with full current flowing through both

coils. In case of coil failure, brake may be operated on one coil for shorter time by shorting out defective coil.

Series Coil Operation - Series brakes are operated with coils connected directly in motor circuit. Due to high currents, coils are connected so that 1/2 of the motor current flows through each brake coil as per Figure 4. In case of coil failure, brake may be operated on one coil for shorter time by disconnecting defective coil.

Removing and Replacing Magnet Coils

Either or both coils may be removed and replaced without disturbing brake adjustment or removing spring load from shoes. Each coil is cast directly in magnet half with epoxy resin and is not repairable except for replacement of flexible leads.

Remove rubber dust shield protecting magnet air gap. Disconnect coil leads inside conduit box and pull leads out of box through rubber grommets for shunt coils or disconnect and unclamp leads for series coils. Remove cotter pin from one end of stop pin 11 in magnet end of brake base and remove stop pin. Unhook tension springs 9 from pin on outside armature and swing outside armature assembly down to rest on floor. Remove 4 bolts holding outer magnet ring from outside of armature and one Allen head cap screw in counter bore in face of center magnet core. Lift coil from brake. Large frame magnets have tapped holes at top for use with eyebolt for lifting.

Leads are covered with insulating compound at the coil terminals. If new leads are required, scrape compound from terminal until hardware is exposed. Replace lead and cover terminals with coat of compound. When changing coils, transfer travel indicator to new magnet. Bolt new magnet in place and bring leads into conduit box through rubber grommets for shunt coils or to terminal board. Make connection to power leads

DC Magnetic Shoe Brakes

per Figure 3 or 4 depending on type of coils being used, and tape leads.

Raise outside armature back up to normal position with bearings of trunnion block 4 engaged in half bearing in outside clapper arms. Hook springs 9 in grooves of spring pin. Replace stop pin 11. Replace rubber dust shield over magnet air gap using new roll pins in magnet if required.

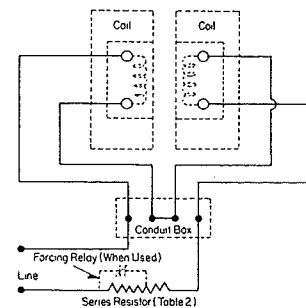

Figure 3: Shunt Coil Connection.

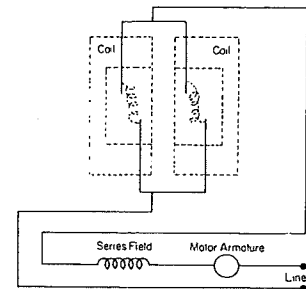

Figure 4: Series Coil Connection.

When installing new magnets, magnet faces may not make even contact due to standard machining tolerances. To avoid stresses and bearing wear resulting from such misalignment

Table 2 Shunt Coil Information

Frame	Standard Shunt Coil Style No.	Cold Coil Resistance OHMS/ Coil	Coil Volts/Coil		Ohms Resistance Required in Line*			
			Cont.	Int.	Continuous		Intermittent	
					OHMS	Amp	OHMS	Amp
" 43	E004051	73	64	80	212	0.88	155	1.1
" 63	E006026	59.4	64	80	171	1.08	125	1.35
83	E008026	31.3	32	40	177	1.0	132	1.28
1035	E010049	23.8	32	40	137	1.35	101	1.68
1355	E013026	19.1	32	40	111	1.68	81	2.1
1665	E016026	8.83	32	40	51.5	3.6	37.7	4.53
1985	E019025	8.51	32	40	49.5	3.8	36.2	4.7
2311	E023026	6.12	32	40	35.6	5.2	26.1	6.54
3014	E030024	4.5	32	40	26.2	7.12	19.1	8.9

* For 250V D.C. without discharge resistor.

* Note - TM43 and 63 frames differ from larger TM brakes since only one coil is used.

Installation and Service Instructions Type TM and TMR

with Rectifier Available for AC Operation

DC Magnetic Shoe Brakes

energize brake to close magnet faces. Loosen bolts holding lever arms to outside armature. This will allow magnets to seat properly. Tighten bolts securely. This operation is required only when replacing either one or both coils.

Right or Left Hand Mounting

Standard mounting is right hand, as in Figure 1, when facing commutator end of motor. Brake magnet is on right side with conduit box next to motor. Shoe bolts are inserted with heads away from motor to allow removal of shoes without dismounting brake.

Left hand or opposite standard mounting with magnet on left involves insertion of shoe bolts from opposite side and interchanging of conduit box and travel equalizer plate. Left hand brake may be ordered as opposite standard from factory or converted in field.

Lubrication

Pivot points in base and lower arms are fitted with porous bronze "oilite" type bearings. A few drops of oil around these bearings occasionally will maintain their lubricated quality. All pivot pins are stainless steel. Pivot pins at top of arms ride in half bearings and are easily accessible. These pins and wear pad contacted by adjusting screw 8 (see Figure 1) should also receive a few drops of oil occasionally.

Failure to Operate

The brake may fail to release for any of the following reasons:

- Lead wire to operating coil may be disconnected.
- Voltage may be below normal.
- Brake may not be adjusted properly. Lining may be worn causing magnet air gap to open beyond point where magnet operates sluggishly or not at all. Re-adjust per adjustment paragraph.

■ One or both coils may be defective. Check coil resistance against Table 2. Compensate for temperature if coil is hot. If one coil is defective, short time emergency operation is possible on one good coil.

■ Coils may be improperly connected with resultant bucking instead of cumulative magnetic flux. Check wiring per wiring per Figure 3 or 4.

Brakes with Hand Release

When specified on order, a lever-type hand release is available as an option at extra cost. The simple mechanism used to open brakes allows for quick release of brake torque for lowering a load in case of power failure. The standard hand release is non-latching and only allows the minimum amount of shoe clearance to allow the wheel to turn. When the brake must be released for extended periods of time such as installation, brake shoe replacement and general maintenance, use of the manual release bushing is recommended.

Overall dimensions of brake are also slightly increased by the hand release linkage.

Replacement Parts

For new coils or other parts, refer to the nearest Sales office giving complete nameplate reading.

